

Articolo / Item
Artículo / Article
Artikel

0176

Gruppo scaldabagno.
Mixer for water heater.
Mezclador para calentador de agua.
Mitigeur pour chauffe-eau
Armatur für Boileranschluss

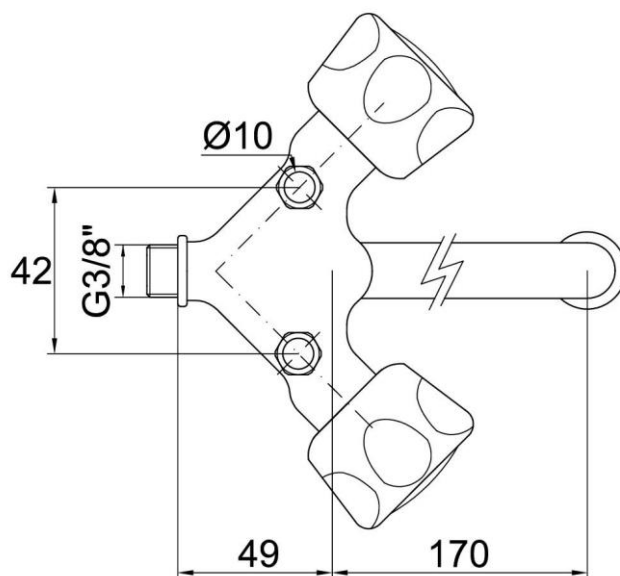

IT



COMPOSIZIONE

- Corpo in ottone cromato

CARATTERISTICHE FUNZIONALI

Pressione di alimentazione: Min 1 – max 6 bar

Pressione raccomandata: 2 – 4 bar

Temperatura di alimentazione: 5 – 65 °C

EN



COMPOSITION

- Chromed brass body

OPERATING CHARACTERISTICS

Operating pressure: Min 1 – max 6 bar

Recommended pressure: 2 – 4 bar

Water inlet temperature: 5 – 65 °C

ES 
COMPOSICIÓN - Cuerpo en latón cromado
CARACTERÍSTICAS FUNCIONALES
Presión de alimentación: Min 1 – max 6 bar
Presión recomendada: 2 – 4 bar
Temperatura de alimentación: 5 – 65 °C

FR 
COMPOSITION - Corps en laiton chromé
CARACTÉRISTIQUES FONCTIONNELLES
Pression d'alimentation: Min 1 – max 6 bar
Pression recommandé: 2 – 4 bar
Température d'alimentation: 5 – 65 °C

DE 
Lieferumfang - Körper aus verchromten Messing
TECHNISCHE EIGENSCHAFTEN
Zulaufdruck: Min 1 – max 6 bar
Empfohlener Zulaufdruck: 2 – 4 bar
Zulauftemperatur: 5 – 65 °C