

**ARTICOLO / Item**  
**Artículo / Article**

**0195/1**

Rubinetto di arresto sottolavabo con filtro estraibile.  
Check valve with extractable filter.  
Llave de paso con filtro extraíble.  
Robinets d'arrêt avec filtre amovible.

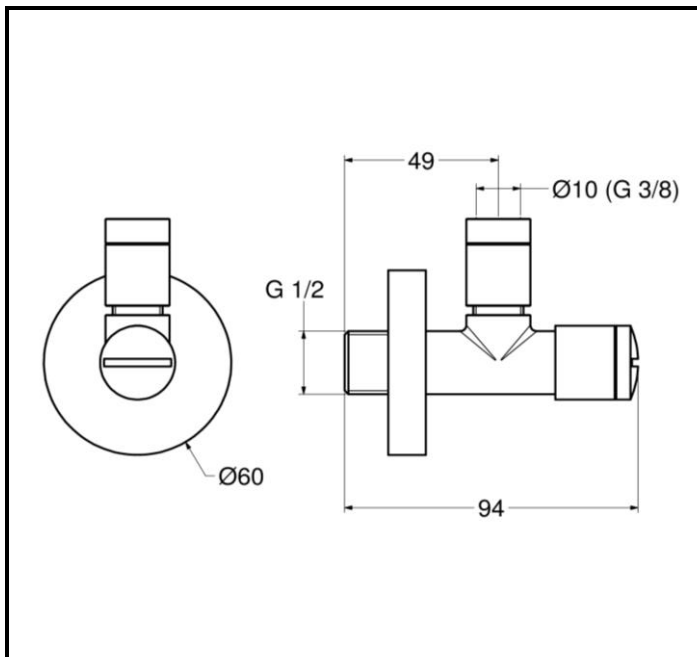

IT



**CARATTERISTICHE FUNZIONALI**

<b>Portata:</b>	28 l/min @ 3 bar
<b>Pressione di servizio:</b>	Min 0,5 – max 10 bar
<b>Temperatura massima di alimentazione:</b>	85 °C
<b>Temperatura raccomandata di alimentazione:</b>	65 °C

EN



**OPERATING CHARACTERISTICS**

<b>Flow rate:</b>	28 l/min @ 3 bar
<b>Working pressure:</b>	Min 0,5 – max 10 bar
<b>Maximum supply water temperature:</b>	85 °C
<b>Maximum recommended water temperature:</b>	65 °C

ES



**CARACTERÍSTICAS FUNCIONALES**

<b>Caudal:</b>	28 l/min @ 3 bar
<b>Presión de servicio:</b>	Min 0,5 – max 10 bar
<b>Temperatura máxima de alimentación:</b>	85 °C
<b>Temperatura recomendada de alimentación:</b>	65 °C

FR



**CARACTÉRISTIQUES FONCTIONNELLES**

<b>Débit:</b>	28 l/min @ 3 bar
<b>Pression de service:</b>	Min 0,5 – max 10 bar
<b>Température maximale d'alimentation:</b>	85 °C
<b>Température recommandé d'alimentation:</b>	65 °C